

Product Data Sheet

Metco TUBE 300 Electric Arc Spray System

The Metco™ TUBE 300 Electric Arc Spray System has been designed to meet the needs of tubing manufacturers, to apply corrosion protective coatings of zinc, aluminum, or zinc-aluminum to welded tube seams in production.

Using the TUBE 300 system, coating of welded tube seams can be performed without interruption of the manufacturing process, online and immediately after scarfing. The TUBE 300 systems applies high quality and very reproducible corrosion protective coatings to the weld seam with low waste, as a result of its narrow spray pattern. TUBE 300 is designed for safe, reliable operation and meets CE standards.

The suitability of this system has been proven at tube manufacturing facilities around the world. Simple and low cost operation, with infrequent change out of consumable parts and high reliability for continuous processing are the key features of the Metco TUBE 300 Electric Arc Spray System.

1 Description

The TUBE 300 Electric Arc Spray System is designed for automated operation. The system comes equipped with all hoses and cables, and is composed of four modules:

- TUBE 300 Wheeled Power Supply
- TUBE 300 Spray Gun (LD/Schub 5) with Tool Post
- TUBE 300 Wire Drive Unit (Push 6)
- TUBE 300 Energy Hose Package

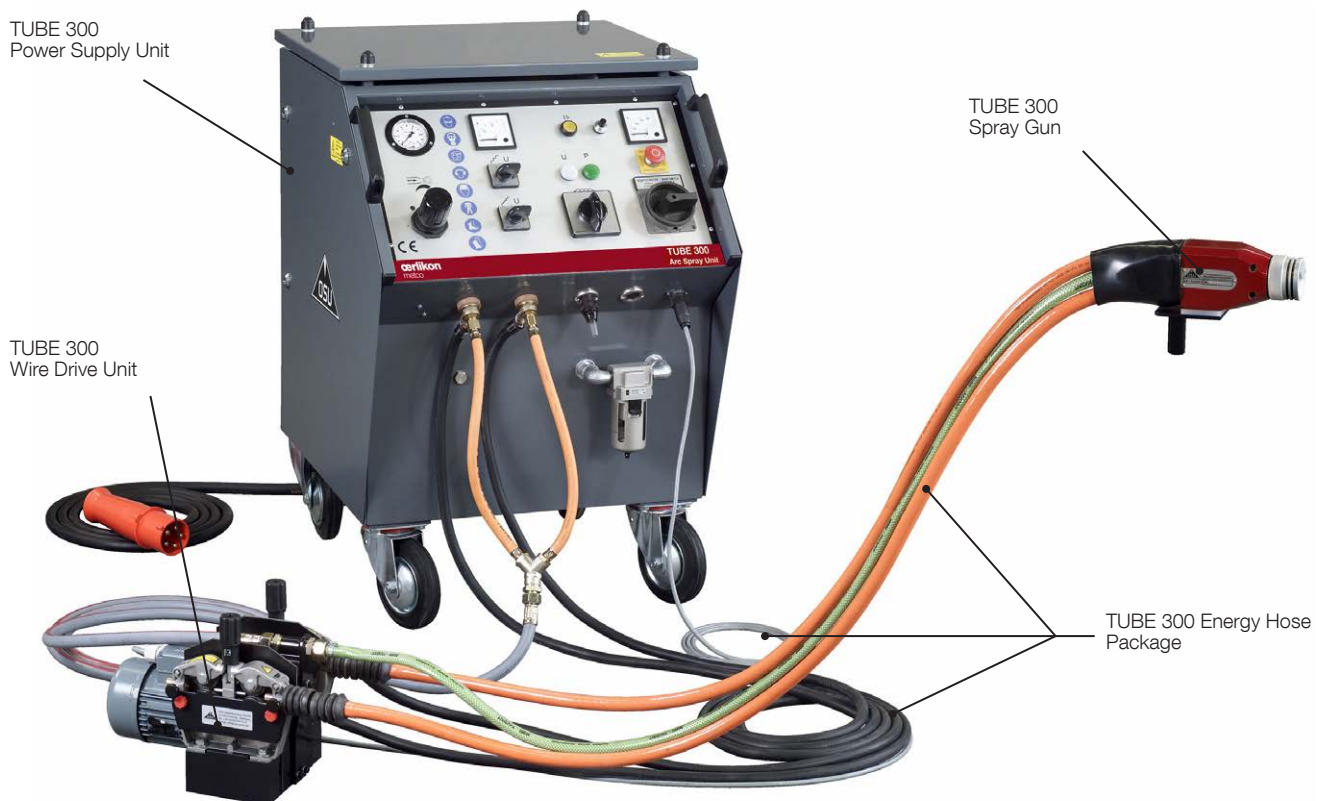

1.1 TUBE 300 Power Supply

The TUBE 300 power supply has been specifically engineered for online coating of tube weld seams. The heart of the TUBE 300 Power Supply is a rugged transformer-rectifier system designed to deliver the system-rated arc current of 300 A at 100 % duty cycle. PLC (programmable logic control) ensures accuracy and repeatability of the system settings.

Start and stop of the spray process is controlled by a signal from an external control system, allowing the TUBE 300 to be integrated directly into an automated tubing production line. Start / stop cycles can be as short as 4 s.

All controls and displays, including those for spray rate and atomizing air pressure, are easily read and accessed on the front panel. Connections for the hose and cable assembly are located on a lower front panel at 45° to prevent strain. Air and electrical supply connections are on the back panel. The unit is mounted on large wheels, making it stable and easy to move.

The internal electrical control elements are well-protected from the environment and spray dust. Convection cooling prevents spray dust getting into the power supply, decreasing the possibility of electrical shorts from metallic dust contamination. The power supply is protected against overloading, overheating and air pressure drops.

1.2 TUBE 300 Spray Gun

The TUBE 300 Wire Spray Gun is easy to use, with simple adjustments, and requires minimal maintenance. Weighing only 1.7 kg (3.7 lb), it can be easily integrated into automated equipment.

The two feedstock wires are passed through our special TUBE 300 long-life contact tips and introduced into the arc at the front of the gun where the wire is melted and the now molten metal is atomized into small particles by compressed air and our unique, hard ceramic air cap.

The atomizing air is fully adjustable and an important factor to control particle size within a well-defined range with a small diameter spray pattern. This ensures the quality of the sprayed coating on the tube weld seam with high deposit efficiency.

1.3 TUBE 300 Wire Drive Unit

The TUBE 300 Wire Drive Unit is a push-type mechanism equipped with variable speed control that continuously transports the wire feedstock material to the spray gun.

The design minimizes the possibility of contamination of the spray system and ensures long service life of the contact tips. Four drive rollers per wire provide slip-free wire transport and avoids chipping of the wire surface. The brushless motor is designed to be maintenance-free. A small, integrated worm gear box controls wire speed to that desired for the application.

Please refer to Section 3.1 for available factory-configurations and optional wire spray kits for various types and sizes of wires.

1.4 TUBE 300 Energy Hose Package

The TUBE 300 Energy Hose Package is composed of:

TUBE 300 Flexible Hose Package has a standard length of 1.5 m (4.9 ft) and consists of two current cables that also feed the wire through specially designed, insulated wire guides, and an air hose for atomizing air. Other hose lengths are available on request.

TUBE 300 Insulated Wire Guides have a standard length of 4 m (13.1 ft) and are made from a low friction material that ensures reliable wire transport.

The length is easily shortened using any simple cutting tool. The guides connect the TUBE 300 Wire Drive Unit to an optional drum or spool holder / decoiler.

TUBE 300 Energy Cable Set has a standard length of 4 m (13.1 ft). The set connects the TUBE 300 Wire Drive Unit with the TUBE 300 Power Supply. It consists of two current cables with ring connectors on each end and a compressed air hose for the atomizing air.

TUBE 300 Remote Control Cable turns the system on and off remotely and can be used for system automation. The cable has a standard length of 4 m (13.1 ft).

2 Features and Benefits

Effective

- Designed specifically for coating tube weld seams.
- Stable arc for reliable, repeatable coatings.
- Integrates into the tube manufacturing line, immediately after weld scarfing.
- Lightweight spray gun can be installed on a wide variety of automated equipment.
- Remote start/stop from external control equipment.
- Adjustable atomizing air controls sprayed particle size range.
- Power supply operates at 300 A, 100 % duty cycle, without overheating or overloading.
- Two-channel emergency stop system integratable in-line.

3 Options and Accessories

Oerlikon Metco supplies a number of options for the TUBE 300 Electric Arc Spray System, including components for spraying different wire sizes and spool types. Please contact your Oerlikon Metco Sales Representative for more information.

Spool adapters: Hasp-style spools are standard. Adapters are available for dorn-style spools and baskets.

Spool Holder / Decoiler: All customers should choose an appropriate drum or spool holder / decoiler. This option holds the wire in place and ensures smooth guidance through the wire feed system. Available for hasp-style spools and drums.

Efficient

- Narrow spray pattern coats narrow seams with very good precision and less waste.
- Simple to use and maintain.

Economical

- Fan-free, convection-cooled power supply prevents contamination from overspray dust.
- Maintenance free, brushless motor.
- Long-life contact tips.

Environmental

- Tight spray pattern for reduced overspray waste.
- Excellent deposit efficiency.

Remote Control Box: Turns system on and off remotely and can be used for manual testing from an automated system.

3.1 Spray Kits

The Metco TUBE 300 Arc Spray System is versatile, and can be used with many different types of wires and wire sizes using optional Spray Kits. All spray kits include the following hardware:

- One (1) air cap
- Two (2) contact tips
- Four (4) pair Push 6 drive and pressure rollers
- Two (2) sets of wire guide tubes for use with the 1.5 m and 4 m hose packages

Spray Kit	Order Number	Wire Type	Wire Size
Hard Wire Spray Kit 1 ^a	1061430	Hard wires	1.6 mm (14 AWG)
Hard Wire Spray Kit 2 ^b	1061431	Hard wires	2.0 mm
Soft Wire Spray Kit 1 ^a	1061432	Zinc, 85Zn/15Al, 95Al/5Mg	1.6 mm (14 AWG)
Soft Wire Spray Kit 2 ^a	1061433	Zinc	2.0 mm
Soft Wire Spray Kit 3 ^a	1061434	Zinc, 85Zn/15Al, 95Al/5Mg	2.5 mm, 2.3 mm (11 AWG)
Soft Wire Spray Kit 4	1061435	85Zn/15Al, 95Al/5Mg	2.0 mm
Soft Wire Spray Kit 5	1061436	Aluminum	1.6 mm (14 AWG)
Soft Wire Spray Kit 6	1061437	Aluminum	2.0 mm
Soft Wire Spray Kit 7	1061438	Aluminum	2.5 mm, 2.3 mm (11 AWG)
Soft Wire Spray Kit 8	1061439	Sprababbitt™, Tin	2.0 mm
Soft Wire Spray Kit 9	1061440	Sprababbitt™, Tin	2.5 mm, 2.3 mm (11 AWG)

^a Can be specified for factory configuration on new spray equipment.

^b Better results are obtained using 1.6 mm wires and high melting point hard wires above 1.6 mm should be completely avoided.

4 Technical Data

4.1 Dimensions

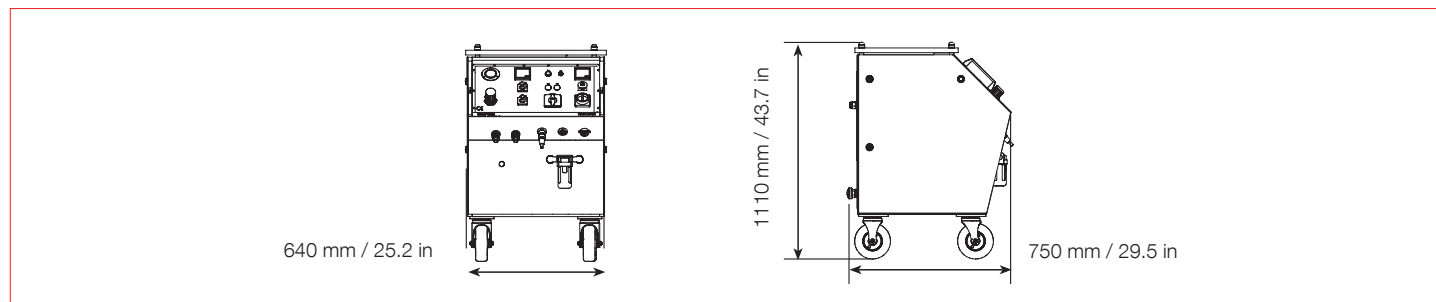

4.2 Specifications

Power supply

Weight (without spool holder device)	228 kg / 503 lb	224 kg / 494 lb	224 kg / 494 lb	224 kg / 494 lb
Electrical requirements ^a	200 V, 50/60 Hz	400 V, 50/60 Hz	415 V, 50/60 Hz	460 V, 50/60 Hz
Primary current	< 35 A	< 18 A	< 17 A	< 17 A
Fuse	50 A	32 A	32 A	32 A
Nominal power	< 11 kVA	< 11 kVA	< 11 kVA	< 11 kVA
Secondary current	300 A	300 A	300 A	300 A
Voltage	18 to 31 V (12 steps)	18 to 31 V (12 steps)	18 to 31 V (12 steps)	18 to 31 V (12 steps)
Open circuit voltage	21 to 36 V	21 to 36 V	21 to 36 V	21 to 36 V
Duty cycle (at full amperage)	100 %	100 %	100 %	100 %
Cooling	Ambient air – convection	Ambient air – convection	Ambient air – convection	Ambient air – convection

Wire Drive Unit

TUBE 300 (Push 6)

Weight	12 kg	26.4 lb
Power (nominal)	0.18 kW	
Speed control type	Inverter	
Wire feed	4 drive rolls per wire	

Spray Gun

LD/Schub 5

Weight (with 1.5 m hose pkg.)	4.6 kg	10.1 lb
Nozzle system	Closed nozzle system	

Air Requirements

Supply pressure (max.)	10 bar	145 psi
Atomizer air	1250 NLPM @ 4 bar	2853 SCFH @ 58 psi
Air purity	Filtered, dry, oil-free, in accordance with DIN ISO 8573 Class 1	
Recooled air temperature (min.)	25 °C	77 °F

Hose and Cable Set

Length ^b	1.5 m (LD/Schub 5) + 4 m	4.9 ft (LD/Schub 5) + 13.1 ft
---------------------	--------------------------	-------------------------------

Wire Materials

Compatibility	All solid electric arc wires available from Oerlikon Metco in appropriate wire sizes (no cored wires)	
Wire diameters	1.6 mm, 2.0 mm, 2.3 mm, 2.5 mm	14 AWG, 0.079 in, 11 AWG, 0.098 in
Spray rates (examples)		
Al	9 kg/h	20 lb/h
Zn	30 kg/h	66 lb/h
85Zn 15Al	26 kg/h	57 lb/h

^a Other voltages available on request

^b Other lengths available on request